

Pearson Edexcel International Advanced Level

Wednesday 15 January 2025

Afternoon (Time: 1 hour 30 minutes)

Paper

reference

WDM11/01

Mathematics

**International Advanced Subsidiary/Advanced Level
Decision Mathematics D1**

You must have:

Decision Mathematics Answer Book (enclosed), calculator

Candidates may use any calculator allowed by Pearson regulations. Calculators must not have the facility for symbolic algebra manipulation, differentiation and integration, or have retrievable mathematical formulae stored in them.

Instructions

- Use **black** ink or ball-point pen.
- If pencil is used for diagrams/sketches/graphs it must be dark (HB or B). Coloured pencils and highlighter pens must not be used.
- **Fill in the boxes** at the top of the answer book with your name, centre number and candidate number.
- Do not return the question paper with the answer book.
- Answer **all** questions and ensure that your answers to parts of questions are clearly labelled.
- Answer the questions in the D1 answer book provided
– *there may be more space than you need.*
- You should show sufficient working to make your methods clear. Answers without working may not gain full credit.
- Inexact answers should be given to three significant figures unless otherwise stated.

Information

- There are 8 questions in this question paper. The total mark for this paper is 75.
- The marks for **each** question are shown in brackets
– *use this as a guide as to how much time to spend on each question.*

Advice

- Read each question carefully before you start to answer it.
- Try to answer every question.
- Check your answers if you have time at the end.
- If you change your mind about an answer, cross it out and put your new answer and any working underneath.

Turn over ►

P76012A

©2025 Pearson Education Ltd.
H:1/1/1/1/



P 7 6 0 1 2 A



Pearson

Write your answers in the D1 answer book for this paper.

1. The following list of eleven numbers is to be packed into bins of size 55

26 19 31 10 14 30 33 18 3 28 5

(a) Use the **first-fit** bin packing algorithm to pack the numbers into bins of size 55 (3)

(b) Use **quick sort** to sort the list into descending order, showing the result after each pass. You must clearly identify the pivots used. (4)

(c) Apply the **first-fit decreasing** bin packing algorithm to pack the numbers into bins of size 55 (2)

(Total for Question 1 is 9 marks)



2.

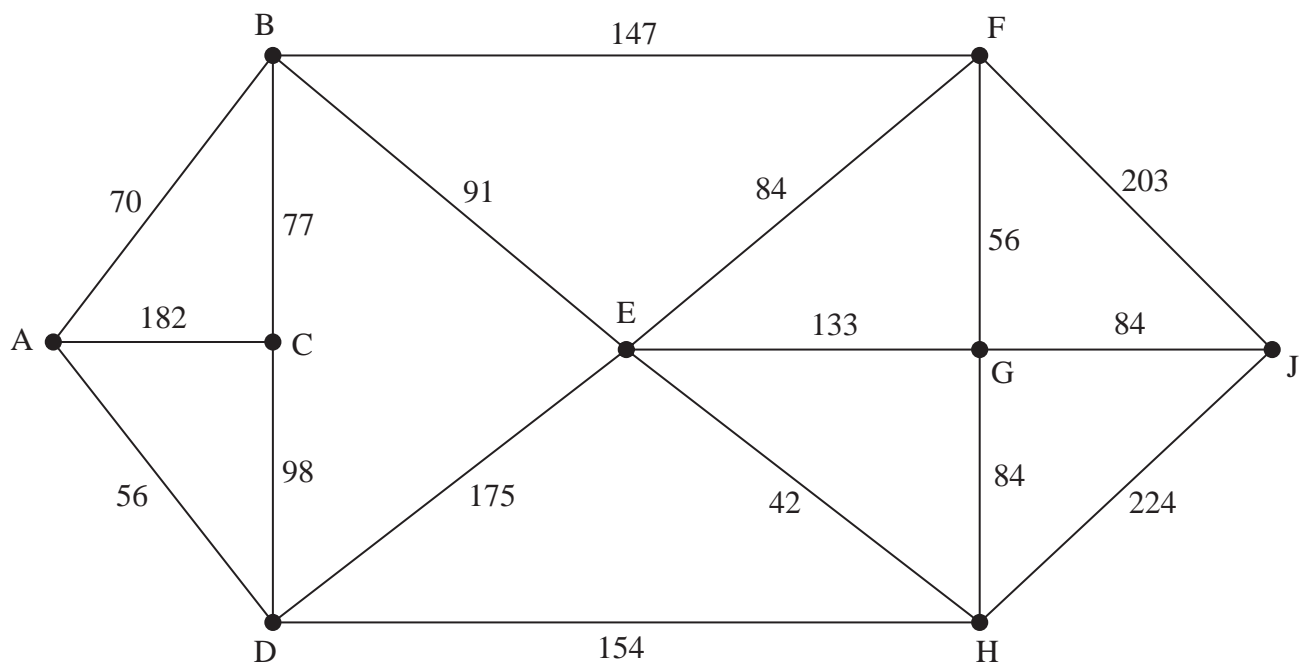

Figure 1

[The total weight of the network is 1960m]

The network shown in Figure 1 represents the paths between nine attractions in a theme park.

The number on each edge is the length, in metres, of the corresponding path.

(a) (i) Use Dijkstra's algorithm to find the shortest path from A to J.

(ii) State the length of the shortest path from A to J in metres.

(6)

Sarita needs to inspect the paths between the attractions. She must travel along each path at least once.

Sarita decides to start and finish her inspection route at A. She wishes to minimise the length of her route.

(b) By considering the pairings of all relevant nodes, find the length of Sarita's route.

(4)

Sarita now decides to start her inspection route at A, but finish at a different attraction. She must still minimise the length of her route and travel along each path at least once.

(c) (i) Determine where Sarita should finish her route. You must justify your answer.

(ii) Calculate the difference between the lengths of the two inspection routes.

(3)

(Total for Question 2 is 13 marks)

3.

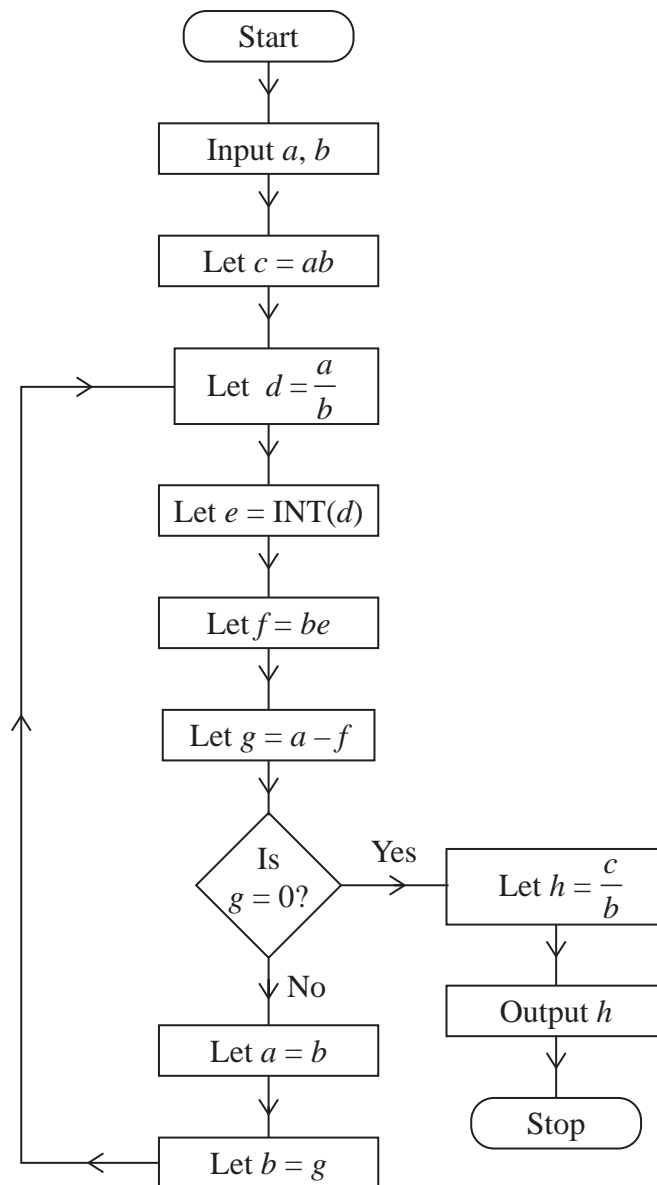

Figure 2

Figure 2 shows the flowchart for an algorithm.

The input for the algorithm is two positive integers.

The function $\text{INT}(X)$ is the largest integer less than or equal to X

(a) Complete the table in the answer book, with $a = 1980$ and $b = 462$, showing the results at each step of the algorithm.

(4)

(b) Explain how the output, h , relates to the inputs, a and b

(1)

(Total for Question 3 is 5 marks)



4.

Activity	Immediately preceding activities
A	-
B	-
C	-
D	A
E	A, B, C
F	A, B, C
G	C
H	D, E, F
I	F
J	F, G
K	F, G

(a) Draw the activity network described in the precedence table above, using activity on arc and the minimum number of dummies.

(5)

Given that

- activity D has a duration of 2 hours
- activity I has a duration of 2 hours
- every other activity has a duration of 1 hour
- D and I are critical activities

(b) determine which other activities are critical.

(1)

(Total for Question 4 is 6 marks)

5. A manufacturer makes three flavours of ice cream, vanilla, strawberry and chocolate. All flavours are supplied in the same size tubs.

The profit from selling each tub of vanilla ice cream is £1.50, each tub of strawberry ice cream is £2.00 and each tub of chocolate ice cream is £1.80

The manufacturer wishes to maximise their profit.

This needs to be formulated as a linear programming problem.

Let x be the number of tubs of vanilla ice cream made.

Let y be the number of tubs of strawberry ice cream made.

Let z be the number of tubs of chocolate ice cream made.

- (a) State the objective, giving the objective function in terms of x , y and z (2)

There are sufficient ingredients to make 400 tubs of vanilla ice cream **or** 240 tubs of strawberry ice cream **or** 300 tubs of chocolate ice cream.

- (b) Show that this constraint can be written as

$$3x + 5y + 4z \leq 1200 \quad (2)$$

The manufacturer must also meet the following three conditions

- at least 40% of the total ice cream made must be vanilla
- at most 25% of the total ice cream made must be strawberry
- for every 2 tubs of strawberry ice cream made, the manufacturer must make at least 3 tubs of chocolate ice cream

- (c) Use this information to form three further constraints, giving these as simplified inequalities with integer coefficients. (3)

(Total for Question 5 is 7 marks)



6.

	A	B	C	D	E	F	G	H	J	K
A	-	16	26	19	22	34	30	41	45	36
B	16	-	10	15	38	33	40	25	29	20
C	26	10	-	12	39	30	31	15	19	10
D	19	15	12	-	33	18	25	28	31	22
E	22	38	39	33	-	15	8	33	20	29
F	34	33	30	18	15	-	7	24	19	28
G	30	40	31	25	8	7	-	25	12	21
H	41	25	15	28	33	24	25	-	13	5
J	45	29	19	31	20	19	12	13	-	9
K	36	20	10	22	29	28	21	5	9	-

- (a) Explain the difference between the **classical** Travelling Salesman Problem and the **practical** Travelling Salesman Problem. (2)

The table shows the shortest distances, in miles, between ten towns, A, B, C, D, E, F, G, H, J and K.

Kenzo must visit each town at least once, starting and finishing at A. Kenzo wishes to minimise the total distance travelled.

- (b) Use Prim's algorithm, starting at A, to obtain a minimum spanning tree for the network. You must clearly state the order in which you select the arcs of your tree. (3)

- (c) Use your answer to part (b) to determine an initial upper bound for the length of Kenzo's route. (1)

- (d) Use the nearest neighbour algorithm, starting at A, to find another upper bound for the length of Kenzo's route. Write down the route that gives this upper bound. (3)

Using the answer to part (d), and given that the length of the nearest neighbour route starting at G is 145 miles,

- (e) state which of these two nearest neighbour routes gives the better upper bound. Give a reason for your answer. (1)

- (f) By deleting A and all of its arcs, obtain a lower bound for the length of Kenzo's route. (2)

- (g) State the smallest interval that must contain the optimal length of Kenzo's route. (1)

(Total for Question 6 is 13 marks)

7.

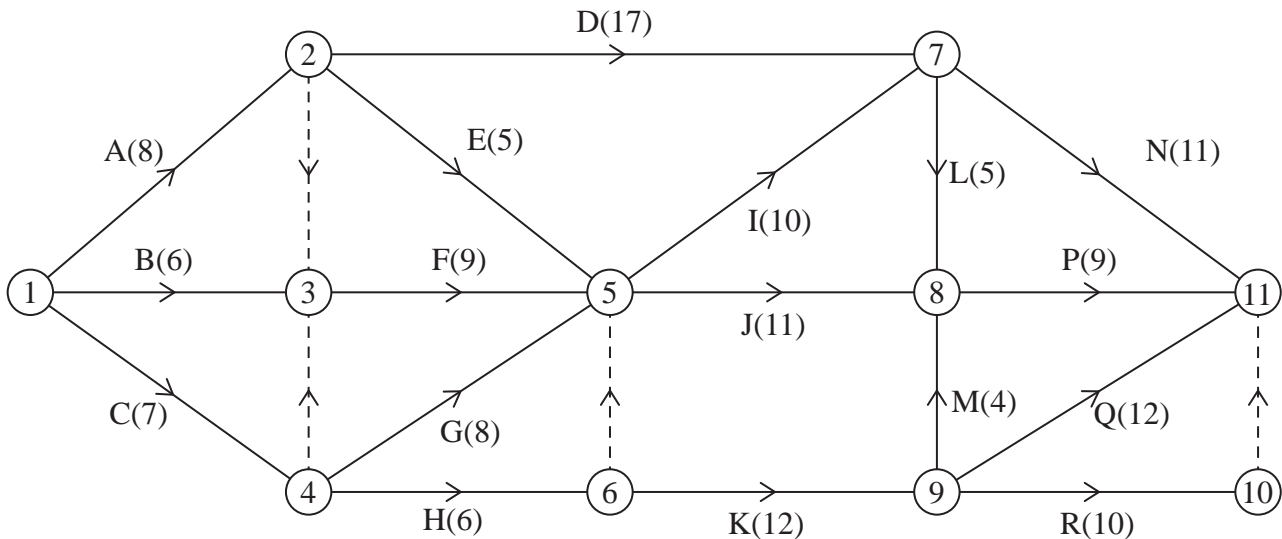

Figure 3

A project is modelled by the activity network shown in Figure 3. The activities are represented by the arcs. The number in brackets on each arc gives the time, in days, to complete the activity. Each activity requires exactly one worker. The project is to be completed in the shortest possible time.

- Explain the purpose of the dummy between event 10 and event 11. (1)
- Complete Diagram 1 in the answer book to show the early event times and the late event times. (4)
- State the critical activities. (1)
- Calculate the maximum number of days by which activity K could be delayed without lengthening the completion time of the project. You must make the numbers used in your calculation clear. (2)
- Draw a Gantt (cascade) chart on the grid in the answer book. (4)
- Use the Gantt chart to determine a lower bound for the minimum number of workers required to complete the project in the minimum time. You must make specific reference to the number of workers, activities and times. (2)

(Total for Question 7 is 14 marks)



8.

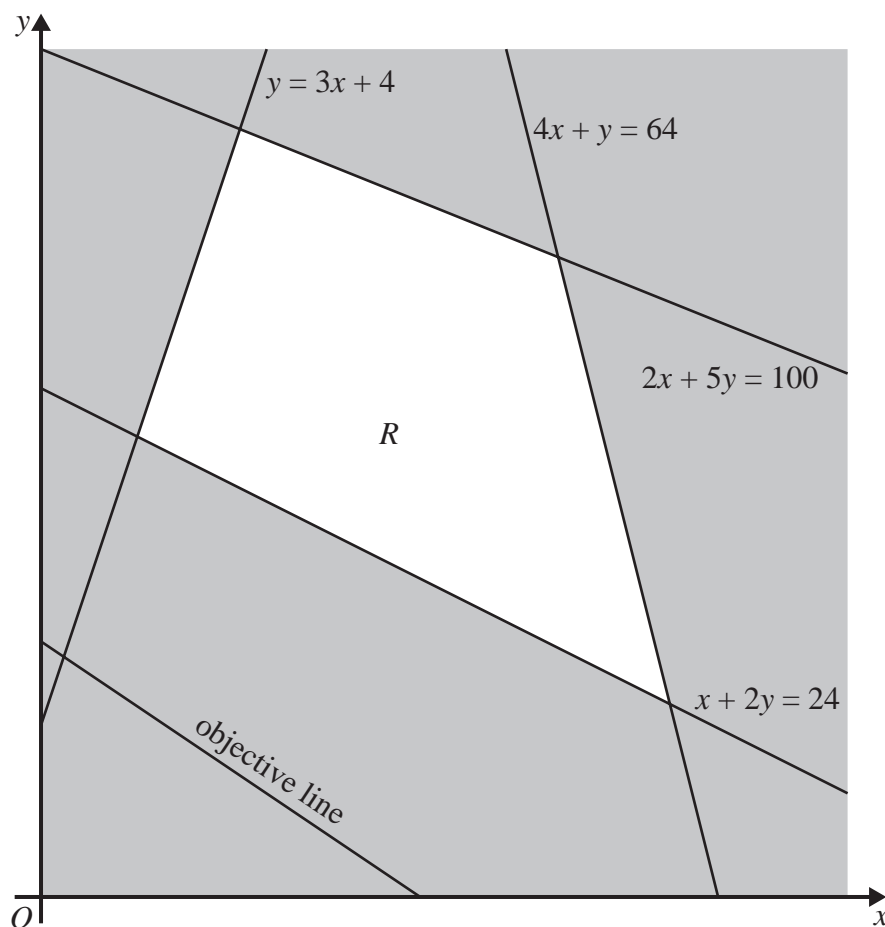

Figure 4

Figure 4 shows the constraints of a linear programming problem in x and y

The unshaded area, including its boundaries, forms the feasible region R

An objective line has been drawn and labelled on the graph.

(a) State the four inequalities that define the feasible region.

(2)

The maximum value of the objective function is $\frac{628}{9}$

The minimum value of the objective function is $\frac{260}{7}$

(b) Determine the objective function, showing your working clearly.

(5)

The practical solution to the linear programming problem requires integer values.

(c) State the minimum integer solution for this problem.

(1)

(Total for Question 8 is 8 marks)

TOTAL FOR PAPER IS 75 MARKS

BLANK PAGE



BLANK PAGE



BLANK PAGE



Please check the examination details below before entering your candidate information

Candidate surname

Other names

Centre Number

Candidate Number

--	--	--	--	--

--	--	--	--	--

Pearson Edexcel International Advanced Level

Wednesday 15 January 2025

Afternoon (Time: 1 hour 30 minutes)

Paper
reference

WDM11/01

Mathematics

**International Advanced Subsidiary/Advanced Level
Decision Mathematics D1**

Answer Book

Do not return the question paper with the answer book.

Total Marks

Turn over ►

P76012A

©2025 Pearson Education Ltd.
H:1/1/1/1/



Pearson

2. (a)

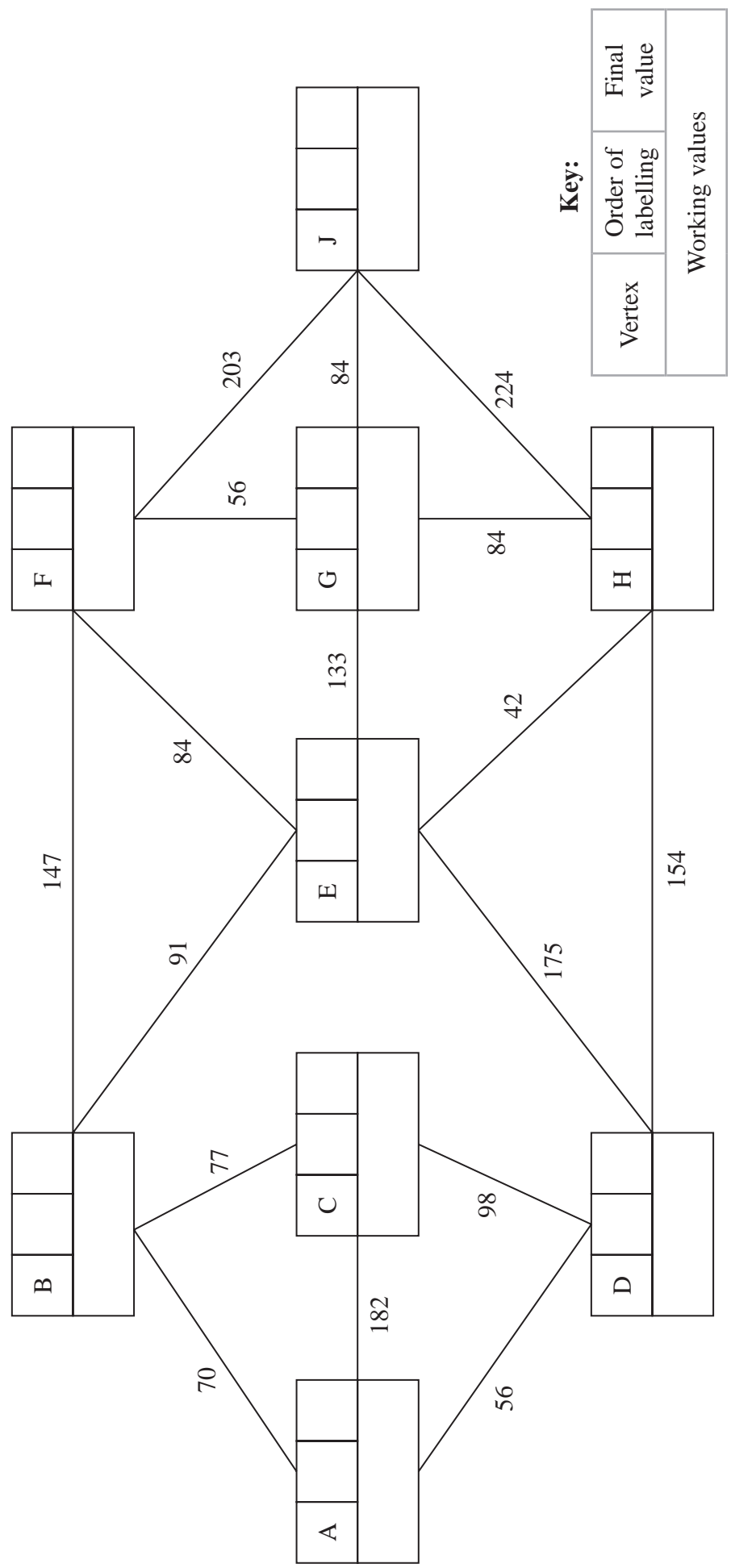

Key:

Vertex	Order of labelling	Final value
Working values		

(i) Shortest path from A to J: _____

(ii) Length of shortest path from A to J: _____



4.

DO NOT WRITE IN THIS AREA

DO NOT WRITE IN THIS AREA

DO NOT WRITE IN THIS AREA



6.

	A	B	C	D	E	F	G	H	J	K
A	-	16	26	19	22	34	30	41	45	36
B	16	-	10	15	38	33	40	25	29	20
C	26	10	-	12	39	30	31	15	19	10
D	19	15	12	-	33	18	25	28	31	22
E	22	38	39	33	-	15	8	33	20	29
F	34	33	30	18	15	-	7	24	19	28
G	30	40	31	25	8	7	-	25	12	21
H	41	25	15	28	33	24	25	-	13	5
J	45	29	19	31	20	19	12	13	-	9
K	36	20	10	22	29	28	21	5	9	-

DO NOT WRITE IN THIS AREA

DO NOT WRITE IN THIS AREA

DO NOT WRITE IN THIS AREA



Question 6 continued

	A	B	C	D	E	F	G	H	J	K
A	-	16	26	19	22	34	30	41	45	36
B	16	-	10	15	38	33	40	25	29	20
C	26	10	-	12	39	30	31	15	19	10
D	19	15	12	-	33	18	25	28	31	22
E	22	38	39	33	-	15	8	33	20	29
F	34	33	30	18	15	-	7	24	19	28
G	30	40	31	25	8	7	-	25	12	21
H	41	25	15	28	33	24	25	-	13	5
J	45	29	19	31	20	19	12	13	-	9
K	36	20	10	22	29	28	21	5	9	-

DO NOT WRITE IN THIS AREA

DO NOT WRITE IN THIS AREA

DO NOT WRITE IN THIS AREA



7.

DO NOT WRITE IN THIS AREA

DO NOT WRITE IN THIS AREA

DO NOT WRITE IN THIS AREA

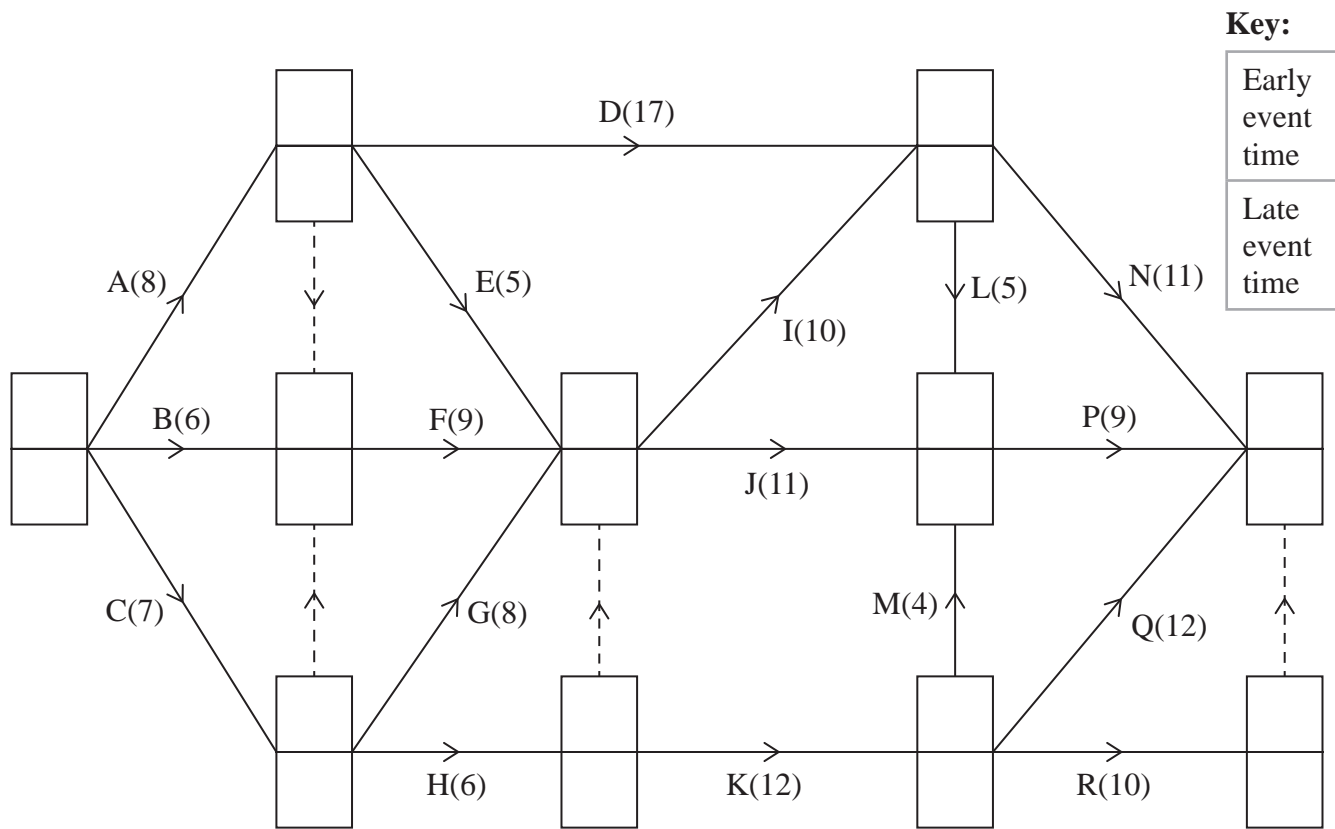
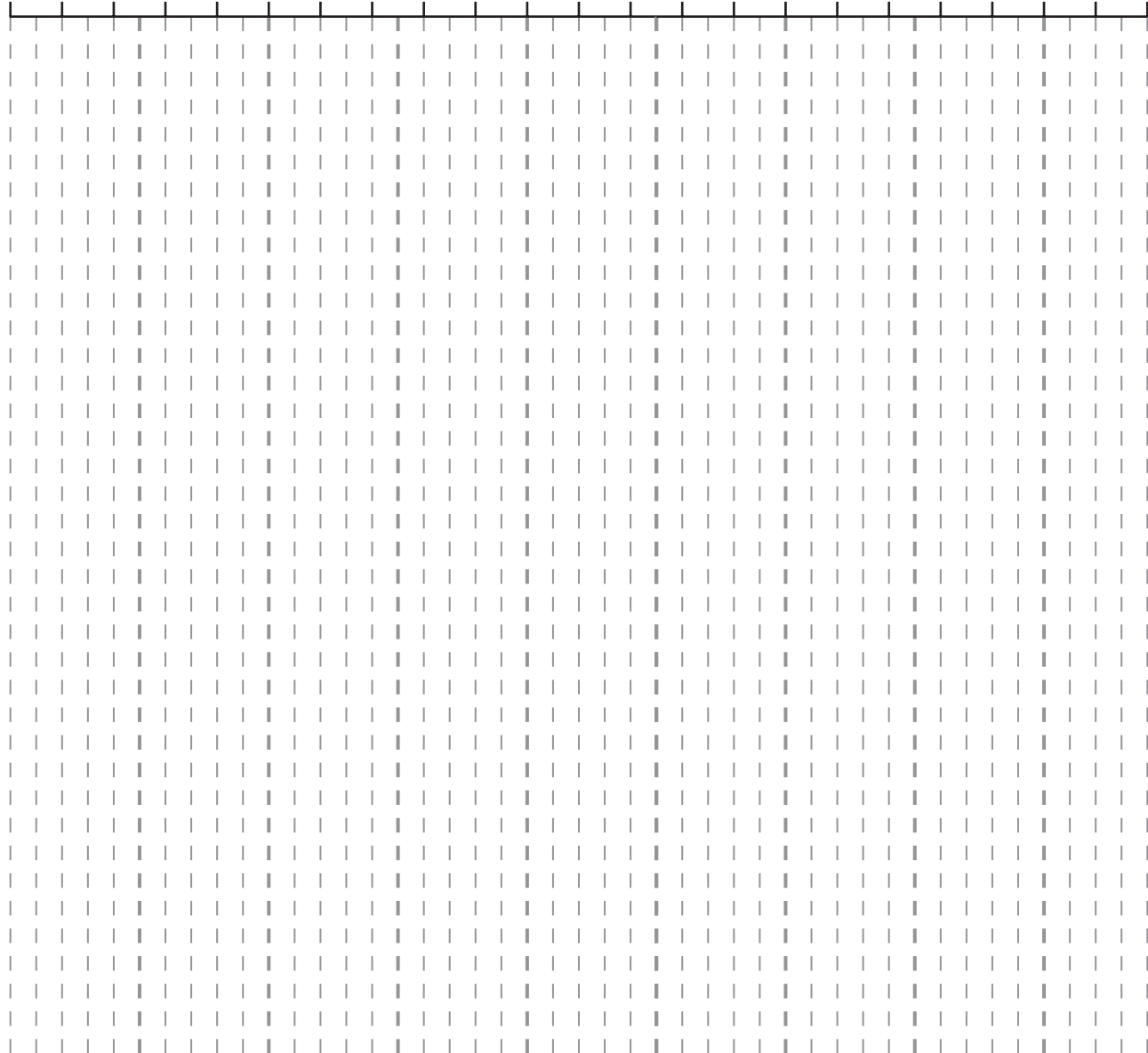

Diagram 1



Question 7 continued

0 2 4 6 8 10 12 14 16 18 20 22 24 26 28 30 32 34 36 38 40 42 44



Handwriting practice lines consisting of ten horizontal lines spaced evenly down the page.

(Total for Question 7 is 14 marks)

DO NOT WRITE IN THIS AREA

DO NOT WRITE IN THIS AREA

DO NOT WRITE IN THIS AREA



P 7 6 0 1 2 A 0 1 7 2 0

